

OSP/OSA Power Pack Series

Provides low voltage power and line voltage control for Leviton Occupancy Sensors



Containing both a 24VDC supply and a 20A line voltage relay for most models, the Leviton compact Power Pack provides low voltage power and line voltage control for Leviton Occupancy Sensors. Versions include Auto-ON and Manual-ON inputs for occupancy sensors, Hold-ON and Hold-OFF capabilities, and a local input for momentary or maintained dry contact switches.

The internal relay can control up to 20A for 120, 230, 277VAC or 347VAC ballast loads and 120VAC incandescent loads. The OSP Power Pack Series is also used to supply power to the OSA Add-A-Relay model. The Power Pack conveniently mounts in a knockout hole of a standard junction box. The unit can be placed inside or outside the junction box with a simple twist-on nut.

APPLICATIONS

Use a Leviton Power Pack with Leviton Occupancy Sensors in the following applications.

- Classrooms
- Conference rooms
- Anywhere optimal lighting and energy savings are desired
- Load shed/Interface hold-OFF applications
- Retail hold-ON/bypass applications
- OSP20
 - Multi-circuit switching
 - Ceiling access lighting and energy management controls

- OSP20-RD
 - Interface to BAS/BMS and HVAC
- OSP20-RDH
 - Bi-Level or A/B lighting
 - Shared emergency lighting
 - Inexpensive 3-Way switching
- OSA20
 - Expanding circuit switching capacity
 - Cost conscious mixed voltage solutions

EASY MOUNTING

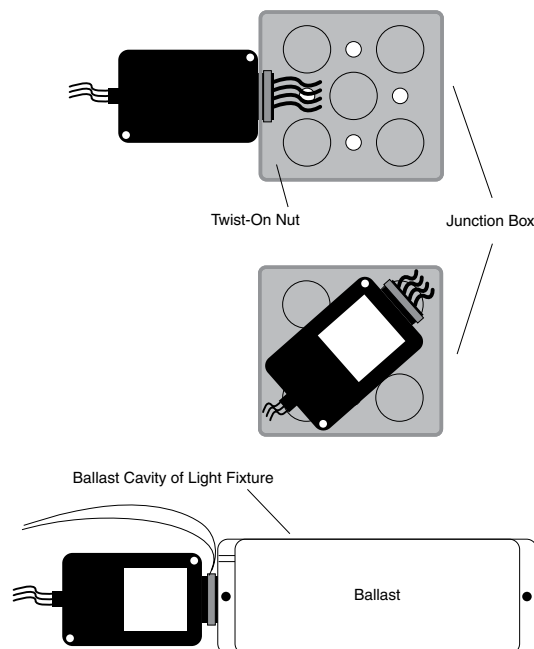

PRODUCT DATA

FEATURES

OSP20-oDo/OSP20-NDo

- Self-contained transformer and relay
- Internal voltage regulator - regulated 24VDC current, 150mA output
- Fast installation - mounts inside or outside junction box, or inside fluorescent ballast cavity with a simple twist-on nut
- Single or multiple luminaire control
- Zero crossing circuitry
- UL 2043 Plenum Rated
- Companion Add-A-Relay provides additional capacity (OSA20-R00)
- NAFTA compliant (OSP20-NDo)
- Made in USA compliant (OSP20-DAo)

OSP20-RDo/OSP15-R30/OSP20-NHo

Includes the same features as the OSP20-oDo, plus:

- Dry contact relay for combined sensor control of lighting and heating/air conditioning
- Dry contact for designing controlled closure
- Form A relay for interface to Building Automation/Management Systems (BAS/BMS)
- NAFTA compliant (OSP20-NHo)
- Made in USA compliant (OSP20-RAD)

OSP20-RDH/OSP20-RNH

Includes the same features as the OSP20-RDo, plus:

- Auto-ON and Manual-ON inputs for occupancy sensors
- "Hold-ON" input - when activated, unit is always ON regardless of any other input
- "Hold-OFF" input - when activated, unit is always OFF regardless of any other input
- Local inputs for momentary or maintained dry contact low voltage switching
- Robust mechanical batching relay designed to perform as a Form C normally closed device
- Increased power supply output to 255mA
- Upon loss of power, latching relay maintains current state (closed or open)
 - H.I.S. >(High In-rush Stability)
 - Heavy duty zero crossing circuitry
- Robust mechanical latching relay
- NAFTA compliant (OSP20-RNH)
- Made in USA compliant (OSP20-RAH)

OSA20-R00/OSA20-RNO

- 15A relay can be added to any OSP20 power pack for flexible design
- For design flexibility when cost conscious
- Inexpensive solution for mixed voltage lighting design
- Used for expanding circuit switching capacity
- Use OSP20 power packs for Emergency Lighting circuits and OSA20 Add-A-Relays for inexpensive control of normal lighting
- NAFTA compliant (OSA20-RNo)
- Made in USA compliant (OSP20-RAo)

DIMENSIONS

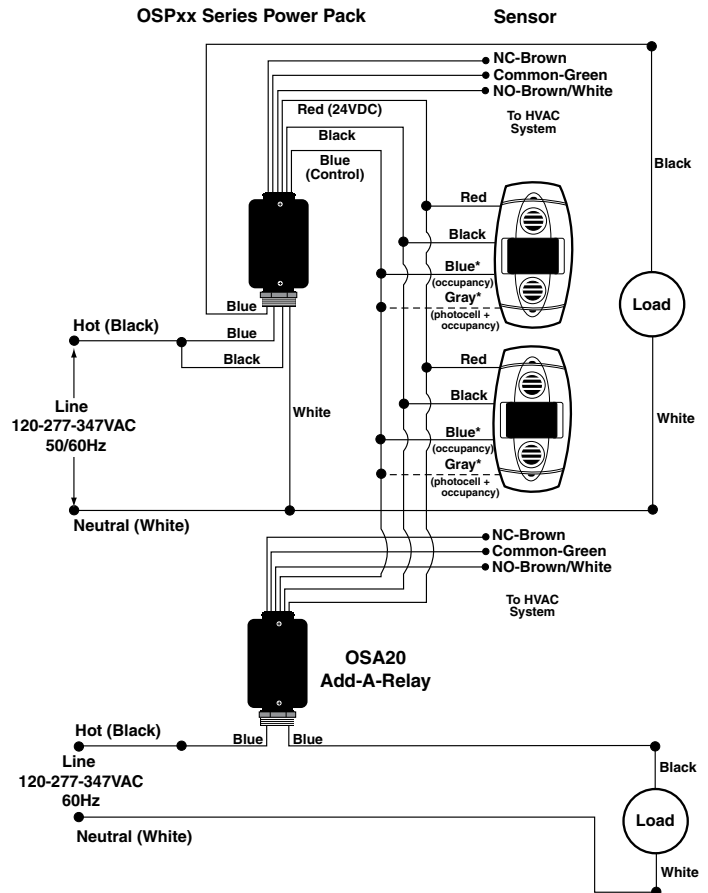
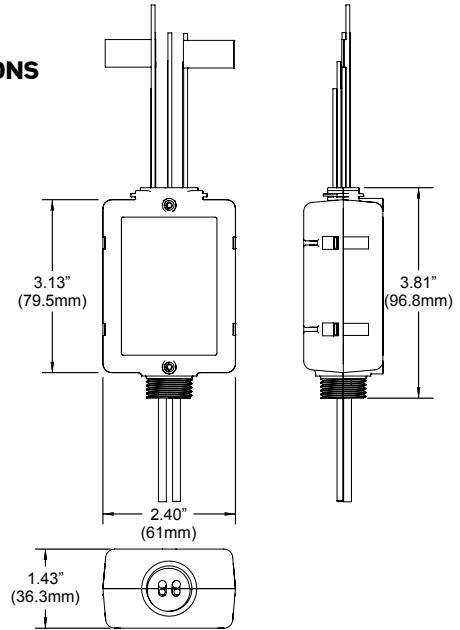

OSP20-RxH Bi-Level Switching

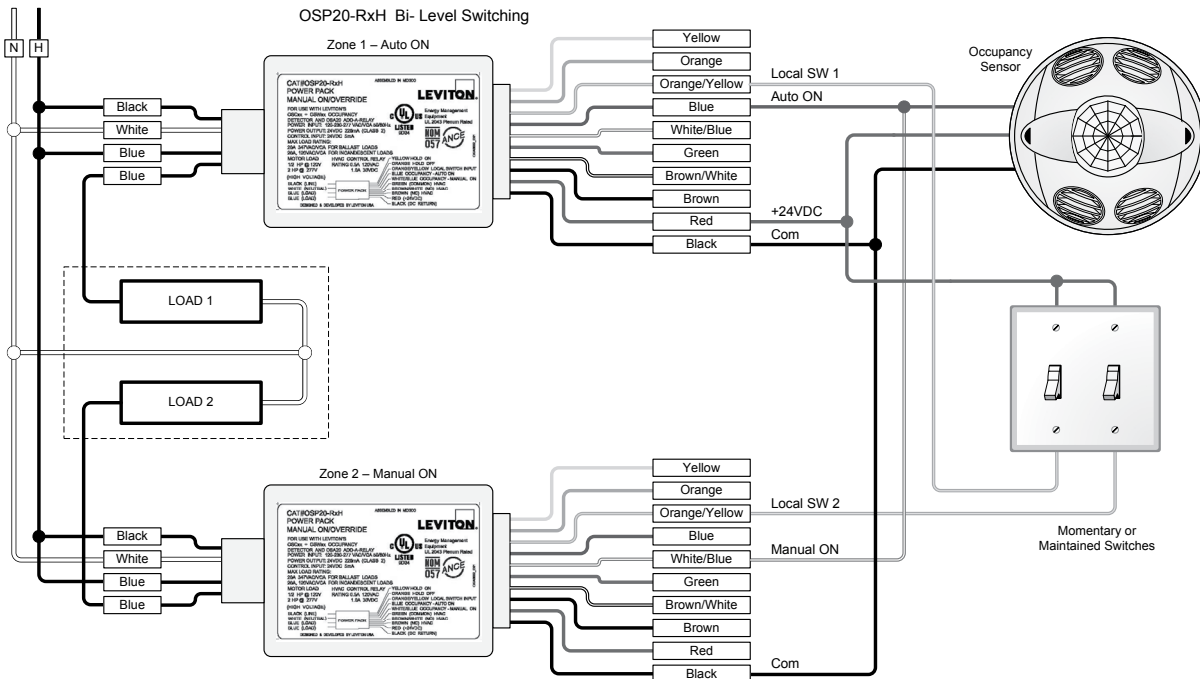

WIRING DESIGNATIONS

SIGNAL TYPE	COLOR	GAUGE
LINE VOLTAGE WIRES		
Line 120-230-277VAC (OSP20-Rxo)	Black	18AWG
Neutral	White	18AWG
Load	Blue	14AWG
Load	Blue	14AWG
CLASS 2 WIRES		
Power (24VDC)	Red	22AWG
DC Return	Black	22AWG
Occupancy Auto-ON	Blue	22AWG
Occupancy Manual-ON	Blue/White	22AWG
Hold-ON	Yellow	22AWG
Hold-OFF	Orange	22AWG
Local Switch Input	Yellow/Orange	22AWG
SIGNAL TYPE	COLOR	GAUGE

HVAC WIRES		
Dry Contact Common	Green	22AWG
Dry Contact NO (Normally Open)	Brown/White	22AWG
Dry Contact NC (Normally Closed)	Brown	22AWG

- All wires rated at 105°C, 600V insulation.
- Class 2 wires are Teflon jacketed, for plenum applications.
- Dry Contact wiring is Class 1 and Class 2 rated.

POWER PACK CAPACITY FORMULA

Leviton power packs can be used to provide power to one or more occupancy sensors. Since current consumptions of occupancy sensors may vary, the best way to ensure you order the correct number of power packs and add-a-relays is by using this formula:

$$\left(\begin{array}{c} \# \text{ of sensor} \\ \text{Model As} \\ \times \\ \text{Sensor A current} \\ \text{consumption rating} \end{array} \right) + \left(\begin{array}{c} \# \text{ of sensor} \\ \text{Model Bs} \\ \times \\ \text{Sensor B current} \\ \text{consumption rating} \end{array} \right) + \left(\begin{array}{c} \# \text{ of Add a} \\ \text{Relays} \\ \times \\ 50\text{mA} \end{array} \right) < 150\text{mA per power pack}$$

DESCRIPTION	CURRENT CONSUMPTION
OSC04-I, OSC15-I, OSWHB-I, OSWLR-I, OSWWV-I	20mA
OSC05-M, OSC05-U, OSW12-M	30mA
OSC10-M, OSC10-U	40mA
OSC20-M, OSC20-U	32mA
OSA20-R00 Add a Relay	50mA

Leviton Mfg. Co., Inc. Lighting & Energy Solutions

201 N. Service Rd. Melville, NY 11747-3138 Tech Line: 1-800-824-3005 Fax: 1-800-832-9538 www.leviton.com/les
 © 2011 Leviton Manufacturing Co., Inc. All rights reserved. Subject to change without notice.

SPECIFICATIONS

ELECTRICAL	
Line Voltage	120-230-277 VAC
Relay Rating	HVAC Relay: 0.5A @ 120VAC, 1.0A @ 30VDC
ENVIRONMENTAL	
Operating Temperature Range	32°F to 104°F (0°C to 40°C)
Relative Humidity	0% to 90% non-condensing, for indoor use only
OTHER	
Construction	Case: high impact, UL rated plastic Relay: class B (130°C) insulating material; silver alloy contacts Wire: 6" leads, 18AWG input; LV connections: 7" leads 22AWG
Dimensions	2.400"H x 3.811"W x 1.432"D (60.96mm x 96.80mm x 36.37mm)
Listings	UL/CUL Listed, FCC Certified, NOM Certified, and meets ASHRAE 90.1 requirements
Color	Black
Warranty	Limited Five-Year Warranty

ORDERING INFORMATION

DESCRIPTION	CAT. NO.	POWER INPUT	RELAY RATING	CONTROL INPUT	POWER SUPPLY OUTPUT
Power Pack	OSP20-oDo	120-230-277VAC, 50/60 Hz	20A fluorescent/incandescent @ 120V, 20A fluorescent @ 230-277V; 1HP @ 120V, 2HP @ 240V	5mA, 24VDC	150mA, 24VDC
Power Pack with Dry Contact Relay	OSP20-RDo	120-230-277VAC, 50/60 Hz	20A fluorescent/incandescent @ 120V, 20A fluorescent @ 277V; 1HP @ 120V, 2HP @ 240V; HVAC: 0.5A @ 120VAC, 1A @ 30VDC	5mA, 24VDC	150mA, 24VDC
Power Pack with Dry Contact Relay	OSP15-R30	347VAC, 60 Hz	15A fluorescent @ 347V; 1HP @ 120V, 2HP @ 240V; HVAC: 0.5A @ 120VAC, 1A @ 30VDC	5mA, 24VDC	120mA, 24VDC
Add-A-Relay Unit with Dry Contact Relay	OSA20-R00	—	15A incandescent @ 120V, 20A fluorescent @ 120V, 20A fluorescent @ 277V, 15A fluorescent @ 347V; HVAC: 0.5A @ 120VAC, 1A @ 30VDC	5mA, 24VDC	—
Power Pack with Dry Contact Relay and Override Inputs for Occupancy Sensors	OSP20-RDH	120-230-277VAC, 50/60Hz	20A fluorescent/incandescent @ 120V; 20A fluorescent @ 277V; 1HP @ 120V, 2HP @ 240V; HVAC: .05A @ 120VAC, 1A @ 20VDC and 15A fluorescent @ 347V; 1HP @ 120V; 2HP @ 240; HVAC: 0.5A @ 120V, 1A @ 30VDC	5mA, 24VDC	225mA, 24VDC

* Consult factory for 208, 220, and 240V models.

LEVITON SPECIFICATION SUBMITTAL

JOB NAME:	CATALOG NUMBERS:
JOB NUMBER:	

Leviton Manufacturing Co., Inc. Lighting & Energy Solutions

201 N. Service Rd. Melville, NY 11747-3138 Tech Line: 1-800-824-3005 Fax: 1-800-832-9538 www.leviton.com/les

Leviton Manufacturing of Canada, Ltd.

165 Hymus Boulevard, Pointe Claire, Quebec H9R 1E9 • Telephone: 1-800-469-7890 • FAX: 1-800-563-1853

Leviton S. de R.L. de C.V.

Lago Tana 43, Mexico DF, Mexico CP 11290 • Tel. (+52) 55-5082-1040 • FAX: (+52) 5386-1797 • www.leviton.com.mx

Visit our Website at: www.leviton.com/les