

# SCU21T-KVM

79121-KVM User Manual

## SCU21T-KVM

### 4K 2x1 HDMI/USB-C Switcher & HDBaseT Receiver



**All Rights Reserved**

**Version: 79121-KVM\_2023V1.1**

[www.tekvox.com](http://www.tekvox.com)

# SCU21T-KVM

## 79121-KVM User Manual

### Preface

Read this user manual carefully before using the product. Pictures shown in this manual are for reference only. Different product model specifications may vary.

This manual is only for operation instruction, please contact the local distributor for maintenance assistance. The functions described in this version were updated February, 2023. In order to continue improving the product, we reserve the right to make function or parameter changes without notice or obligation. Please refer to the dealers for the latest details.

### FCC Statement

This equipment generates, uses, and can radiate radio frequency energy and, if not installed and used in accordance with the instructions, may cause harmful interference to radio communications. It has been tested and found to comply with the limits for a Class A digital device, pursuant to part 15 of the FCC Rules. These limits are designed to provide reasonable protection against harmful interference in a commercial installation.

Operation of this equipment in a residential area is likely to cause interference, in which case the user at their own expense will be required to take whatever measures may be necessary to correct the interference.

Any changes or modifications not expressly approved by the manufacture would void the user's authority to operate the equipment.



# SCU21T-KVM

## 79121-KVM User Manual

### **Safety Precautions**

To ensure the best performance from the product, please read all instructions carefully before using the device. Save this manual for further reference.

- Unpack the equipment carefully, and save the original box and packing material for possible future shipment
- Follow basic safety precautions to reduce the risk of fire, electrical shock, and injury
- Do not dismantle the housing or modify the module (electrical shock or burn hazard)
- Using supplies or parts not meeting the products' specifications may cause damage, deterioration, or malfunction
- Refer all servicing to qualified service personnel
- To prevent fire or shock hazard, do not expose the unit to rain or moisture, or install this product near water
- Do not put any heavy items on the product's power cable
- Do not remove the housing of the device, as opening or removing the housing may expose you to dangerous voltages or other hazards
- Install the device in a place with sufficient ventilation to avoid damage caused by overheating
- Keep the module away from liquids
- Spillage into the housing may result in fire, electrical shock, or equipment damage. If an object or liquid falls or spills on to the housing, unplug the module immediately.
- Do not twist or pull by force ends of the optical cable. It can cause malfunction.
- Do not use liquid or aerosol cleaners to clean this unit. Always unplug the power to the device before cleaning.
- Unplug the power cord when left unused for a long period of time
- Information on disposal for scrapped devices: do not burn or mix with general household waste, please treat them as normal electrical wastes

### Table of Contents

<b>1. Product Introduction .....</b>	<b>6</b>
1.1 Features .....	6
<b>2. Specifications .....</b>	<b>7</b>
<b>3. Panel Description .....</b>	<b>9</b>
3.1 Transmitter .....	9
3.1.1 Front Panel .....	9
3.1.2 Rear Panel.....	10
3.2 Receiver .....	11
3.2.1 Front Panel .....	11
3.2.2 Rear Panel.....	11
<b>4. EDID Management.....</b>	<b>12</b>
<b>5. GUI Control .....</b>	<b>13</b>
5.1 Video Tab.....	14
5.2 Configuration Tab .....	14
5.2.1 EDID .....	14
5.2.2 Auto-Downscaling.....	15
5.2.3 HDCP .....	15
5.2.4 Tags .....	16
5.3 CEC Tab .....	17
5.3.1 Input .....	17
5.3.2 Output .....	17
5.3.3 User-Defined.....	18
5.4 RS232 Tab .....	18
5.5 Network Tab.....	19
5.6 Access Tab.....	20
<b>6. RS232 Control.....</b>	<b>21</b>
6.1 System Control.....	21
6.2 Source Control.....	23

# SCU21T-KVM

## 79121-KVM User Manual

<b>7. System Connection .....</b>	<b>27</b>
<b>8. Panel Drawing .....</b>	<b>30</b>

# SCU21T-KVM

## 79121-KVM User Manual

### 1. Product Introduction

TEKVOX's SCU21T-KVM is a 4K 2x1 HDMI/USB-C switcher with simultaneous HDMI and HDBaseT video outputs, audio de-embedding, and automatic source detection & switching. The switcher is capable of transmitting 4K video, audio, RS232 control, bi-directional 48V PoC, USB camera/microphone feeds, and Ethernet LAN up to 100m (328ft) via HDBaseT. Connected user laptops can access and use any USB devices connected to the DEVICE ports on either the switcher or its receiver, and the USB-C input supports up to 60W charging for connected devices.

With its streamlined yet versatile design, the SCU21T-KVM is the perfect switcher for sophisticated, modern video conferencing in any space and any application.

#### 1.1 Features

- HDMI and USB-C (with 60W charging) video inputs
- USB-B and USB-C USB hosts for video conferencing and touchscreen connection
- Supports 4Kx2K@60Hz 4:4:4 resolutions, HDR10
- Supports automatic source detection and switching
- Controllable via RS232, CEC, or front panel buttons
- Simultaneous HDMI and HDBaseT video outputs
- 100m (328ft) HDBaseT transmission with bi-directional 48V PoC

# SCU21T-KVM

## 79121-KVM User Manual

### 2. Specifications

	Transmitter	Receiver
<b>Video</b>		
<b>Inputs</b>	1x HDMI (19-pin, Type-A, Female) 1x USB-C (Type-C, Female)	1x HDBaseT (RJ45, Female)
<b>Input Resolution</b>	<b>HDMI:</b> Up to 4Kx2K @ 60Hz 4:4:4, HDR10, Dolby Vision <b>USB-C:</b> Up to 4Kx2K @ 60Hz 4:4:4	Up to 4Kx2K @ 60Hz 4:2:0
<b>Outputs</b>	1x HDMI (19-pin, Type-A, Female) 1x HDBaseT (RJ45, Female)	1x HDMI (19-pin, Type-A, Female)
<b>Output Resolution</b>	<b>HDMI:</b> Up to 4Kx2K @ 60Hz 4:4:4, HDR10, Dolby Vision <b>HDBaseT:</b> Up to 4Kx2K @ 60Hz 4:2:0	Up to 4Kx2K @ 60Hz 4:4:4, HDR10, Dolby Vision
<b>Compliances</b>	<b>HDMI:</b> Up to 2.0b <b>HDCP:</b> Up to 2.2	
<b>Audio</b>		
<b>Audio Output</b>	1x Balanced Stereo (5-pin terminal block)	1x Balanced Stereo (5-pin terminal block)
<b>Audio Format</b>	PCM 2.0	
<b>Frequency Response</b>	20Hz ~ 20kHz, ±3dB	
<b>Maximum Output Level</b>	0.88VRMS ±0.5dB	
<b>Total Harmonic Distortion + Noise (THD+N)</b>	< 0.05% (-80 dB), 20 Hz – 20 kHz bandwidth, 1 kHz sine at 0 dBFS level (or max level)	
<b>Signal-to-Noise Ratio (SNR)</b>	> 80dB, 20Hz ~ 20kHz bandwidth	
<b>Crosstalk Isolation</b>	< -80dB, 10kHz sine at 0dBFS level (or max level before clipping)	
<b>L-R Level Deviation</b>	< 0.3dB, 1kHz sine at 0dBFS level (or max level before clipping)	
<b>Output Load Capability</b>	1kΩ and higher (supports 10x parallel 10kΩ loads)	

# SCU21T-KVM

## 79121-KVM User Manual

<b>Noise Level</b>	> 70dB @ 1kHz	
<b>Control</b>		
<b>Control Ports</b>	1x EDID Switch (4-pin DIP switch) 2x DEVICES (USB 3.0, Type-A, Female) 1x ETHERNET (RJ45, female) 1x Firmware (Micro-USB, Female) 1x HOST (USB 3.0, Type-B, Female) 2x GR (3-pin terminal block) 2x RS232 (3-pin terminal block) 1x TCP/IP (RJ45, Female)	3x DEVICES (USB 2.0, Type-A, Female) 1x DEVICES (USB 2.0, Type-C, Female) 1x ETHERNET (RJ45, Female) 1x RS232, 3-pin terminal block)
<b>General</b>		
<b>Operating Temperature</b>	23 ~ 131°F (-5 ~ 55°C)	
<b>Storage Temperature</b>	-13 ~ 158°F (-25 ~ 70°C)	
<b>Operating Humidity</b>	10 ~ 90%, non-condensing	
<b>Power Supply</b>	<b>Input:</b> AC 100 ~ 240V, 50/60Hz <b>Output:</b> DC 24V, 5A	48V Power-over-Cable (PoC)
<b>Transmission Distance</b>	328 feet (100m)	
<b>Bandwidth</b>	18Gbps	
<b>Power Consumption</b>	76.5W (max)	
<b>USB-C Charging Power Delivery</b>	60W (max)	
<b>Product Dimensions</b>	10.4" (265mm) x 5.9" (150mm) x 1.3" (32mm)	6.8" (173mm) x 3.7" (95mm) x 0.96" (24.5mm)
<b>Product Weight</b>	2.25lbs. (1020g)	0.9lbs. (410g)



# SCU21T-KVM

## 79121-KVM User Manual

### 3. Panel Description

#### 3.1 Transmitter

##### 3.1.1 Front Panel

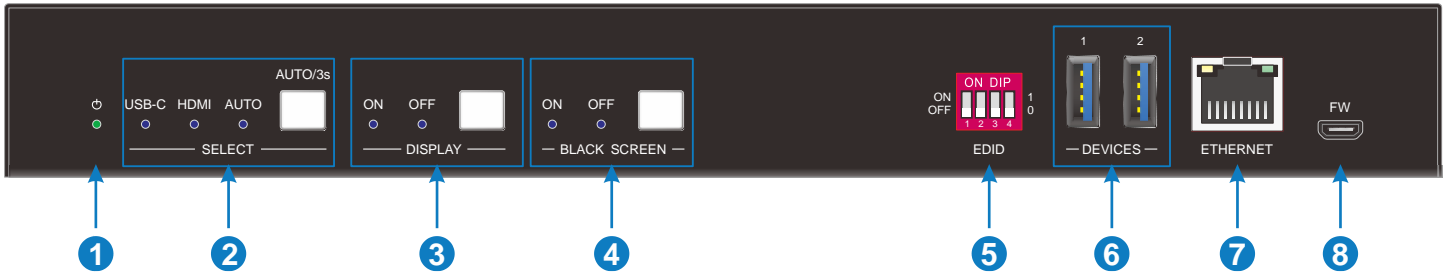

No.	Name	Description
1	Power LED	1x green indicator light; light is always on when the switcher has power and is working normally, and goes out when power is off
2	SELECT	1x white non-backlit button, 3x blue indicator lights Press the button the change input source (HDMI or USB-C); press and hold for at least 3 seconds to toggle auto-switching mode The indicator light of the selected source will always be on
3	DISPLAY	1x white non-backlit button, 2x blue indicator lights Press the button to send the DISPLAY ON/OFF CEC and RS232 commands to the TX and RX terminals switches The indicator light for the display's current state will always be on
4	BLACK SCREEN	1x white non-backlit button, 2x indicator lights Press the button to temporarily suppress video output (shows a black screen) The indicator light for the video output's current state will always be on
5	EDID	1x 4-pin DIP switch for EDID management
6	DEVICES	2x USB 3.0 for connecting a camera, microphone, or other equipment
7	ETHERNET	1x RJ45 used for network passthrough transmission via HDBaseT
8	FW	1x Micro-USB for MCU firmware upgrades

# SCU21T-KVM

## 79121-KVM User Manual

### 3.1.2 Rear Panel

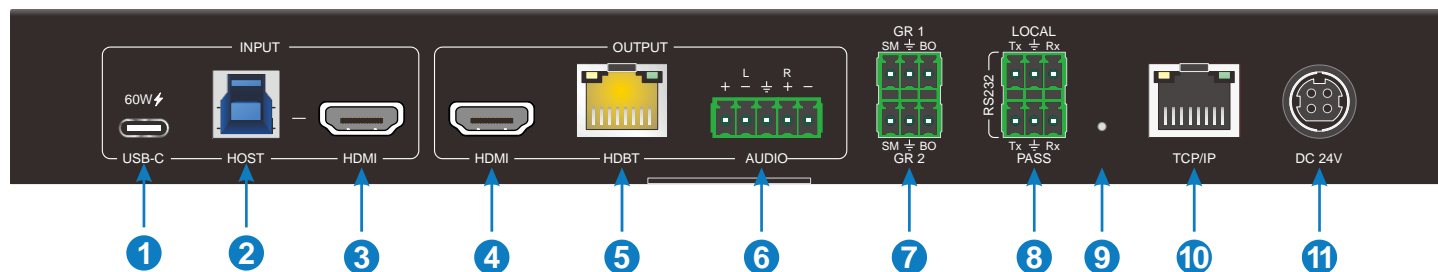

No.	Name	Description
1	USB-C	1x USB-C 3.0 input; supports 60W charging for connected devices
2	HOST	1x USB 3.0 port for connecting to HOST devices (such as a laptop)
3	HDMI IN	1x HDMI input for connecting to HOST devices (such as a laptop)
4	HDMI OUT	1x HDMI loop output
5	HDBASET	1x HDBaseT output The green indicator light is always on when HDCP is detected, and flashes when an input signal without HDCP is detected The yellow indicator light is always on when the TX and RX are properly connected
6	AUDIO OUT	1x 5-pin balanced stereo audio output for audio de-embedding
7	Grommet	GR1 corresponds to the USB-C input GR2 corresponds to the HDMI input <b>SM</b> : Switches to the corresponding video input source <b>BO</b> : Temporarily suppresses video output (outputs a black screen) on the corresponding video input source
8	RS232	<b>LOCAL</b> : For connecting control devices to control the transmitter <b>PASS</b> : Bi-directional passthrough transmission via HDBaseT
9	Upgrade	1x Firmware Upgrade button Press and hold for 3 seconds to enter Upgrade Mode, and the power indicator will start flashing; users can then upgrade the unit's firmware via the RS232 port Press again to exit Upgrade Mode
10	TCP/IP	1x RJ45 for TCP/IP control
11	DC 24V	Connect DC 24V, 5A power adapter

# SCU21T-KVM

## 79121-KVM User Manual

### 3.2 Receiver

#### 3.2.1 Front Panel

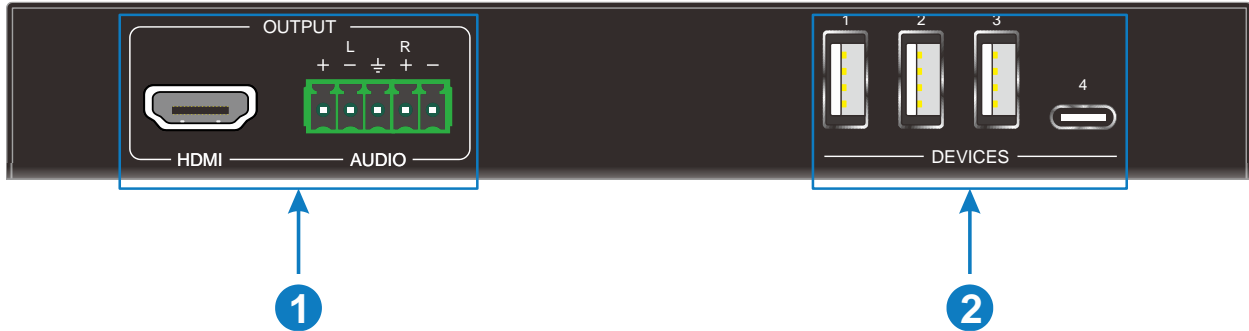

No.	Name	Description
1	OUTPUT	1x HDMI Output 1x 5-pin balanced stereo audio output for audio de-embedding
2	DEVICES	2x USB-A 2.0, 1x USB-C for connecting a keyboard, mouse, camera, microphone, or other equipment

#### 3.2.2 Rear Panel

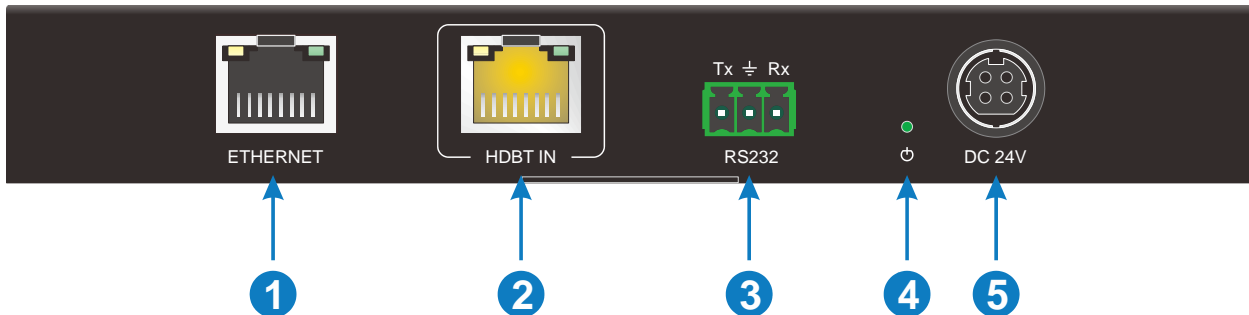

No.	Name	Description
1	ETHERNET	1x RJ45 for network passthrough transmission via HDBaseT
2	HDBT IN	1x RJ45 HDBaseT input The green indicator light is always on when HDCP is detected, and flashes when an input signal without HDCP is detected The yellow indicator light is always on when the TX and RX are properly connected
3	RS232	1x 3-pin connector for RS232 passthrough transmission via HDBaseT
4	Power LED	1x green indicator light; always on when receiver has power and is working normally
5	DC 24V	Connect DC 24V, 5A power adapter

# SCU21T-KVM

## 79121-KVM User Manual

### 4. EDID Management

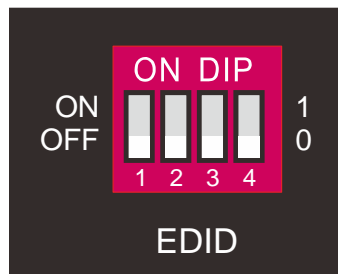

EDID settings for the switcher are controlled by the EDID DIP switches as described below. In the following table, “0” indicates a switch in the Off or Down position, while “1” indicates a switch in the ON or UP position.

DIP Switch Position	EDID Behavior
0000	Switcher will automatically read the EDID of the transmitter and receiver HDMI outputs, and set its EDID to the lower of the two. If EDID cannot be detected, the switcher will default to 1920x1080@60 8bit Stereo.
0001	1920x1080 @ 60Hz 8-bit High Definition Audio
0010	3840x2160 @ 60Hz Deep Color Stereo Audio
0011	3840x2160 @ 30Hz 8-bit Stereo Audio
0100	3840x2160 @ 30Hz Deep Color High Definition Audio
0101	3840x2160 @ 60Hz 4:2:0 Deep Color Stereo Audio
0110	3840x2160 @ 60Hz Deep Color High Definition Audio
0111	3840x2160 @ 60Hz Deep Color HDR LPCM 6CH
1011	Custom EDID1
1100	Custom EDID2
1101	Custom EDID3
1110	Custom EDID4
1111	EDID Management

# SCU21T-KVM

## 79121-KVM User Manual

### 5. GUI Control

The SCU21T-KVM can be controlled via TCP/IP protocols. The default IP settings are:

**IP Address:** 132.168.0.178

**Subnet Mask:** 255.255.255.0

**Gateway:** 192.168.0.1

Type the IP address of the switcher into a web browser on the control PC to open the web GUI login page.



**Username:** admin

**Password:** admin

Enter the username and password, then click “Login” to open the web GUI.

# SCU21T-KVM

## 79121-KVM User Manual

### 5.1 Video Tab



Select HDMI or USB-C as the active video input source, or toggle Auto-Switching mode

### 5.2 Configuration Tab

#### 5.2.1 EDID

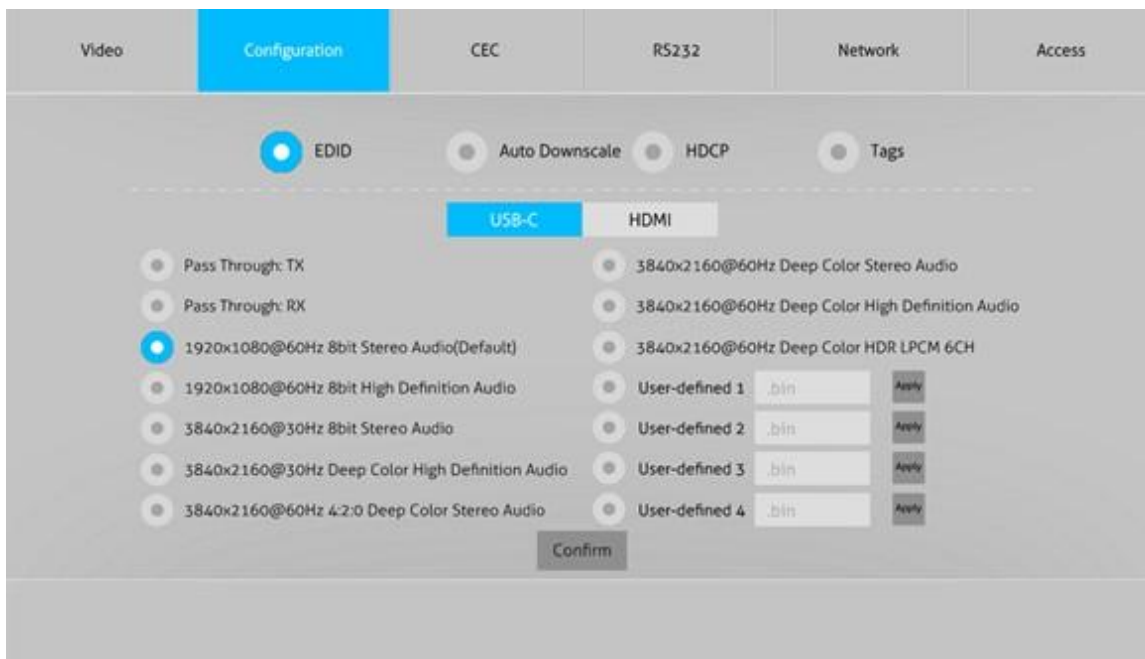

Choose the desired EDID format, or define a custom EDID setting

# SCU21T-KVM

## 79121-KVM User Manual

### 5.2.2 Auto-Downscaling



Enable or disable automatic down-scaling for the transmitter and receiver video outputs

### 5.2.3 HDCP



Choose whether to have the HDCP for the transmitter and receiver follow the source or display

# SCU21T-KVM

## 79121-KVM User Manual

### 5.2.4 Tags



Customize the tags for the HDMI and USB-C inputs, and for the transmitter and receiver HDMI outputs



# SCU21T-KVM

## 79121-KVM User Manual

### 5.3 CEC Tab

#### 5.3.1 Input



Click to send the corresponding CEC command to the device connected to the HDMI input

#### 5.3.2 Output



Click to send the corresponding CEC command to the device connected to either the transmitter or receiver's HDMI output

# SCU21T-KVM

## 79121-KVM User Manual

### 5.3.3 User-Defined



The screenshot shows the CEC configuration interface. At the top, there are tabs for Video, Configuration, CEC, RS232, Network, and Access. The CEC tab is selected. Below the tabs, there are sub-tabs for Input, Output, and User-defined. The User-defined tab is selected. The interface is divided into two main sections: Input and Output. The Input section has two radio buttons: USB-C (unselected) and HDMI (selected). Below each radio button are two trigger fields: Trigger 1 and Trigger 2. Each trigger field has a text input box and a Send button. The Output section has two radio buttons: Tx Output (selected) and Rx Output (unselected). Below each radio button are two trigger fields: Trigger 1 and Trigger 2. Each trigger field has a text input box and a Send button.

Define custom CEC commands to send to either the transmitter or receiver's HDMI inputs or outputs. Click "Send" next to a custom command to send to the corresponding input or output

### 5.4 RS232 Tab

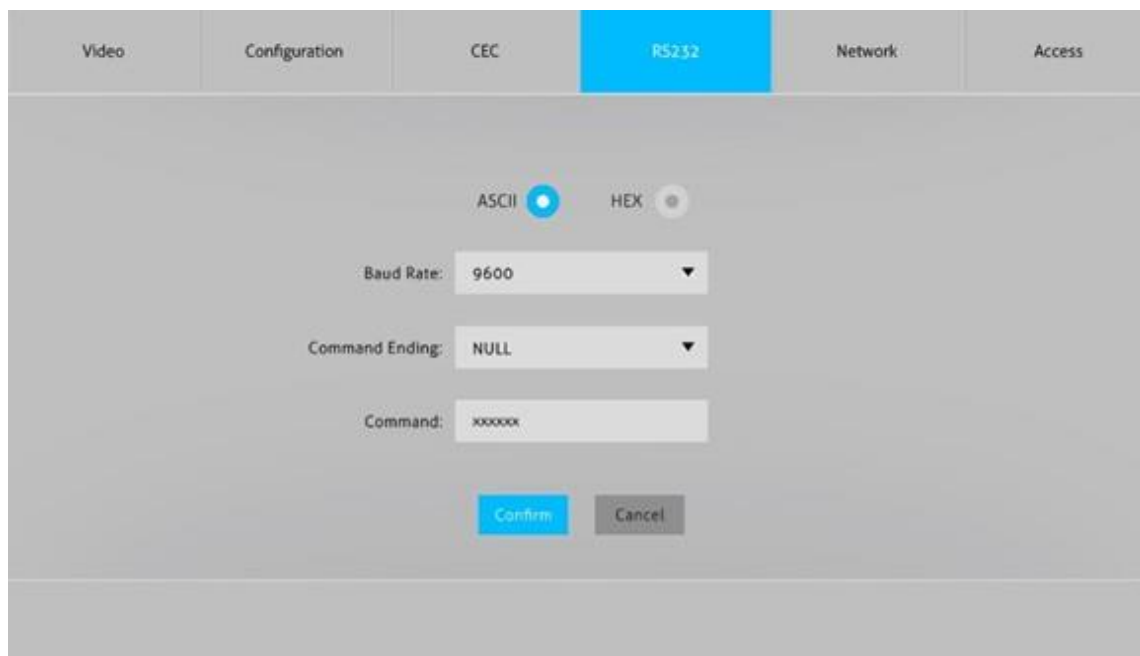

The screenshot shows the RS232 configuration interface. At the top, there are tabs for Video, Configuration, CEC, RS232, Network, and Access. The RS232 tab is selected. The interface has two radio buttons: ASCII (selected) and HEX (unselected). Below the radio buttons are three fields: Baud Rate (9600), Command Ending (NULL), and Command (xxxxxx). At the bottom, there are two buttons: Confirm and Cancel.

Choose whether to format RS232 commands as ASCII or HEX characters

# SCU21T-KVM

## 79121-KVM User Manual

**Baud Rate:** 9600, 19200, 38400, 57600, 115200

**Command Ending:** NULL, CR, LF, or CR+LF

**Command:** Type an RS232 command to send to the third-party device connected to the RS232 port

### 5.5 Network Tab



The screenshot shows the Network configuration interface. At the top, there are tabs for Video, Configuration, CEC, RS232, Network (selected), and Access. The Network tab displays the MAC Address as 44-33-4C-C9-35-12. Below this, there are two radio buttons: DHCP (unselected) and Static IP (selected). Under the Static IP option, there are three input fields: IP Address (192.168.0.178), Subnet Mask (255.255.255.0), and Gateway (192.168.0.1). A blue Confirm button is located at the bottom of the form.

Choose whether the switcher is set to a Static IP address or gets a DHCP automatically from the network DHCP server

Set the IP Address, Subnet Mask, and Gateway of the switcher (only available when set to Static IP)

# SCU21T-KVM

## 79121-KVM User Manual

### 5.6 Access Tab

The screenshot displays the 'Access' tab of the SCU21T-KVM web GUI. The top navigation bar includes tabs for Video, Configuration, CEC, RS232, Network, and Access (highlighted in blue). The main content area is divided into three sections:

- Password:** A text input field contains the text 'admin', followed by a 'Confirm' button.
- Firmware Upgrade:** A text input field contains the text 'C:\', followed by a 'Confirm' button.
- Front Panel Lock:** A toggle switch is shown, currently set to 'OFF'.

**Password:** Modify the password for accessing the web GUI

**Firmware Upgrade:** Browse to the file location of the firmware upgrade file in the computer's file explorer. Press "Confirm" while the switcher is in Upgrade Mode to update its firmware.

**Front Panel Lock:** Lock or unlock the front panels buttons for controlling the switcher

# SCU21T-KVM

## 79121-KVM User Manual

### 6. RS232 Control

Before controlling the SCU21T-KVM, make sure that all relevant inputs and outputs are connected, and that the COM port, baud rate, data bit, stop bit, and parity bit are set correctly.

**Baud Rate:** 9600

**Data Bit:** 8

**Stop Bit:** 1

**Parity Bit:** None

#### 6.1 System Control

All commands should be terminated with "<CR><LF>"

Command	Description	Command & Feedback Example
PHDBTON.	Turn HDBaseT PoC On	HDBT 01 Power ON!
PHDBTOFF.	Turn HDBaseT PoC Off	HDBT 01 Power OFF!
HDMI.A.	Set to Auto-Switching Mode	HDMI Out Switch Auto Mode!
HDMIM.	Set to Manual-Switching Mode	HDMI Out Switch Manual Mode!
HDMI[x].	Select video input source x = 1 ~ 2 1: USB-C Input 2: HDMI Input	HDMI Out Switch to 01! HDMI Out Switch to 01!
POWON.	Turn switcher on	Power ON!
POWOFF.	Turn switcher off	Power OFF!
SIGNALTRG[x]MODE.	Set auto-switching detection method x = 1 ~ 2 1: 5V Detection 2: TMDS Detection	Set Trigger Mode to 5V.
SIGNALTRGSTA.	Query the signal detection method (TMDS or 5V)	Get Trigger Mode is 5V.
RST	Restore factory default settings	Factory Default!
Lock.	Lock front panel buttons	Front Panel Locked!
Unlock.	Unlock front panel buttons	Front Panel UnLock!

# SCU21T-KVM

## 79121-KVM User Manual

Command	Description	Command & Feedback Example
STA.	Query device status	SCU21T-KVM V1.0.0 PWON! HDBT 01 Power ON! HDMI Out 01 Down Scale OFF! HDMI Out 02 Down Scale OFF! HDMI Out Switch Auto Mode! Get Trigger Mode is 5V. System Unlock! Baudrate 9600! GUI_IP:192.168.0.200! HDMI Out Switch 02! Set Output Black Screen ON! IN 1 2 LINK Y Y OUT 1 2 LINK Y Y Input 1 EDID From 1 User Define EDID! Input 2 EDID From 1 Internal EDID! OUT 01 HDCP MAT DISPLAY! OUT 02 HDCP MAT DISPLAY! Set POF Delay to 600 Second(s)!
RS232ONSAVE:[y].[xxx]	Set an RS232 power on command to be sent to the display when an input is detected  y = Baud Rate, 1 ~ 7 1: 2400 2: 4800 3: 9600 4: 19200 5: 38400	Save PON Command:YYYYY,Baudrate is 9600!

# SCU21T-KVM

## 79121-KVM User Manual

Command	Description	Command & Feedback Example
	<b>6:</b> 57600 <b>7:</b> 115200 <b>[xxx]</b> = RS232 command	
RS232OFFSAVE: <b>[y],[xxx]</b> .	Set an RS232 display off command to be sent when no input is detected <b>y</b> = Baud Rate, 1 ~ 7 <b>1:</b> 2400 <b>2:</b> 4800 <b>3:</b> 9600 <b>4:</b> 19200 <b>5:</b> 38400 <b>6:</b> 57600 <b>7:</b> 115200 <b>[xxx]</b> = RS232 command	Save POFF Command:TTTTTT,Baudrate is 9600!
RS232DLYOUT <b>[xx]:[yy]</b>	Set how long the switcher will wait before sending the display power off command after no input is detected. Default is 10 minutes (600s) <b>xx</b> = 00 <b>yy</b> = seconds	Set POFF Delay To 10 Second(s)!

## 6.2 Source Control

Command	Description	Command & Feedback Example
TVON.	Turn on display via CEC command	CEC_TC_POWON! CEC Output 01 Send Success. CEC Output 02 Send Success.
TVOFF.	Turn off display via CEC command	CEC_TV_POWOFF! CEC Output 01 Send Success. CEC Output 02 Send Success.
TVVOL+.	Increase display volume via CEC command	CEC_TV_VOLUP! CEC Output 01 Send Success. CEC Output 02 Send Success.
TVVOL-.	Decrease display volume via CEC command	CEC_TV_VOLDOWN! CEC Output 01 Send Success. CEC Output 02 Send Success.

# SCU21T-KVM

## 79121-KVM User Manual

Command	Description	Command & Feedback Example
TVMUTE.	Mute display audio via CEC command	CEC_TC_VOLMUTE/UNMUTE! CEC Output 01 Send Success. CEC Output 02 Send Success.
HDCP[x]PAS.	Set the output HDCP to follow the input <b>x</b> = 0 ~ 2 <b>0</b> : All outputs	OUT 01 HDCP PASSIVE! OUT 02 HDCP PASSIVE!
HDCP[x]MAT.	Set the output HDCP to follow the display <b>x</b> = 0 ~ 2 <b>0</b> : All outputs	OUT 01 HDCP MAT Display! OUT 02 HDCP MAT Display!
HDCP[x]ON.	Forces HDCP1.4 open on the output <b>x</b> = 0 ~ 2 <b>0</b> : All outputs	OUT 01 HDCP ON! OUT 02 HDCP ON!
HDCP[x]OFF.	Forces HDCP closed on the output <b>x</b> = 0 ~ 2 <b>0</b> : All outputs	OUT 01 HDCP OFF! OUT 02 HDCP OFF!
DS[x]ON.	Enable downscaling on the HDMI output <b>x</b> = 0 ~ 2 <b>0</b> : All outputs	HDMI OUT 01 Down Scale ON! HDMI OUT 02 Down Scale ON!
DS[x]OFF.	Disable downscaling on the HDMI output <b>x</b> = 0 ~ 2 <b>0</b> : All outputs	HDMI OUT 01 Down Scale OFF! HDMI OUT 02 Down Scale OFF!
STA_IN.	Get source connection status	IN 1 2 LINK N N
/+[x]:yyy.	Send an RS232 command to control a connected third-party device <b>x</b> = Baud rate, 1 ~ 7 <b>1</b> : 2400 <b>2</b> : 4800 <b>3</b> : 9600 <b>4</b> : 19200 <b>5</b> : 38400 <b>6</b> : 57600	123456



# SCU21T-KVM

## 79121-KVM User Manual

Command	Description	Command & Feedback Example
	<b>7:</b> 115200 <b>yyy</b> = RS232 command	
@OUT[xx].	Turn off the HDMI output's 5V, making it undetectable as an active source <b>x</b> = Output port, <b>00</b> ~ <b>01</b> <b>00</b> : All outputs	Set Output Black Screen ON!
\$OUT[xx].	Turn on the HDMI output's 5V, making it detectable as an active source <b>x</b> = Output port, <b>00</b> ~ <b>01</b> <b>00</b> : All outputs	Set Output Black Screen OFF!
GETUIIP.	Get the web GUI IP address	GUI_IP:192.168.0.173!
SetGuiIP_DHCPON.	Set switcher to Dynamic IP address (DHCP)	GUI IP DHCP ON!
SetGuiIP_DHCPOFF: xxx.xxx.x.xxx.	Set switcher to static IP address (default is 192.168.0.178)	GUI IP DHCP OFF!SETGUIIP:192.168.0.123!
EDIDUpgrade[xx].	Upgrades EDID data via serial port (requires additional software)  <b>xx</b> = Input port, <b>00</b> ~ <b>02</b> <b>x</b> : All inputs Custom EDID is applied setting, but not saved in switcher memory  OR  <b>xx</b> = User-defined EDID, <b>U1</b> ~ <b>U4</b> Only one user-defined EDID can be customized at once, and the switcher will not automatically switch to the custom EDID after upgrading  Ensure that all HDBaseT is disconnected before sending command	

# SCU21T-KVM

## 79121-KVM User Manual

Command	Description	Command & Feedback Example
EDID/[xx]/[yy].	Set input port <b>xx</b> to use EDID setting <b>yy</b> <b>xx</b> = 00 ~ 02 00: All input ports <b>yy</b> = 01 ~ 12 <b>01</b> ~ <b>08</b> : Built-in EDID (cannot be changed) <b>09</b> ~ <b>12</b> : User-defined EDID	Input 02 EDID Upgrade OK By 01 Internal EDID!
EDIDM[x]B[y].	Set input port <b>y</b> to inherit EDID from output <b>x</b> <b>x</b> = 1 ~ 2 <b>y</b> = 0 ~ 2 <b>0</b> : All input ports	Input 01 EDID Upgrade OK By 02 EXT EDID!
Baudrate[xx].	Set the RS232 baud rate to <b>xx</b> <b>xx</b> = 9600, 19200, 38400, 57600, or 115200	Set Local RS232 Baudrate Is 9600!
CEC[x][AA][BB][CC][DD].	Send custom CEC command <b>x</b> = Input or output port, <b>I</b> or <b>O</b> <b>AA</b> = Port number, <b>01</b> ~ <b>02</b> FF: All ports <b>BB</b> = Device Type (e.g. TV: <b>40/20/80</b> , Blu-ray Player: <b>04/08</b> , etc.) <b>CC</b> = CEC Function Category <b>DD</b> = CEC command to be sent (e.g. "41" for Volume +); can send up to 9 combined commands	

# SCU21T-KVM

## 79121-KVM User Manual

### 7. System Connection

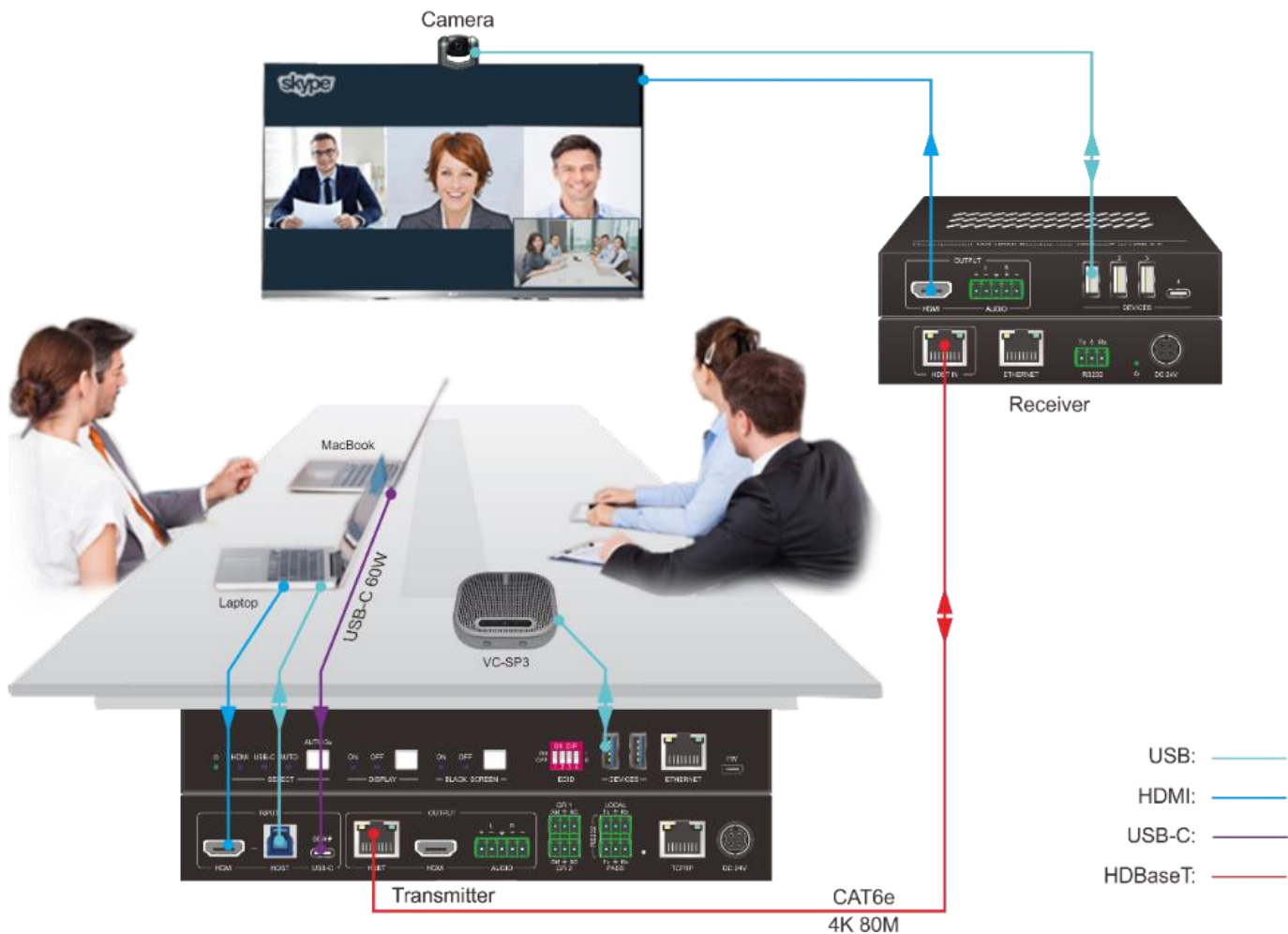
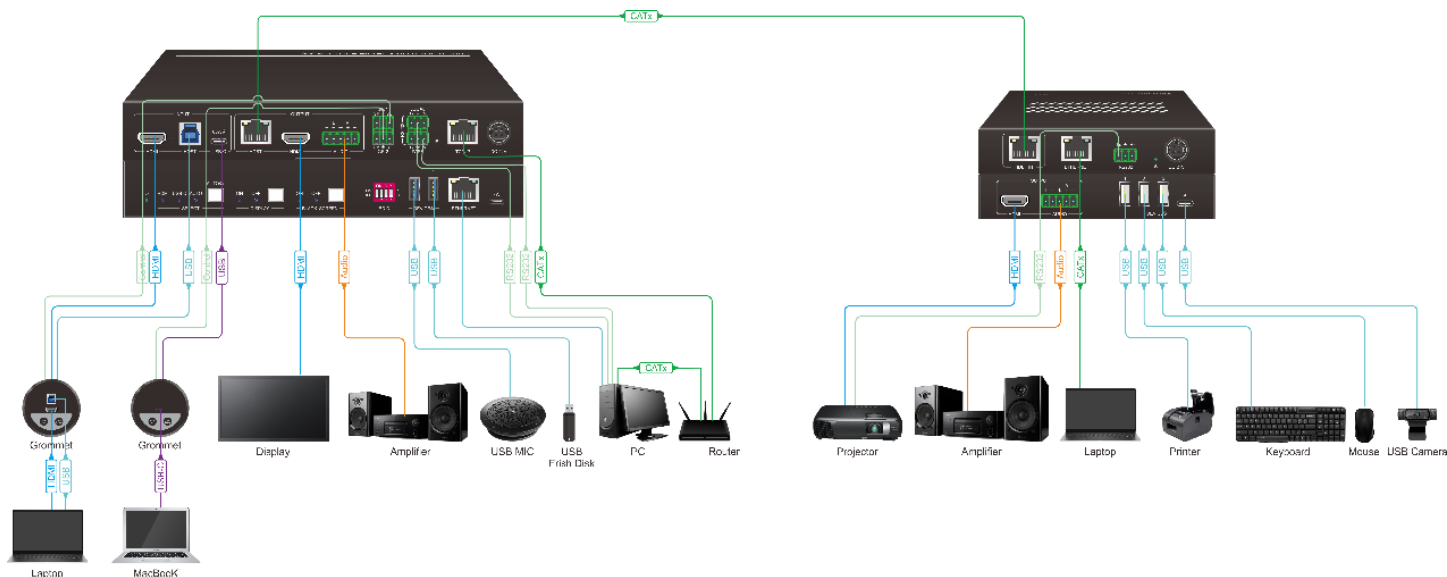

# SCU21T-KVM

## 79121-KVM User Manual

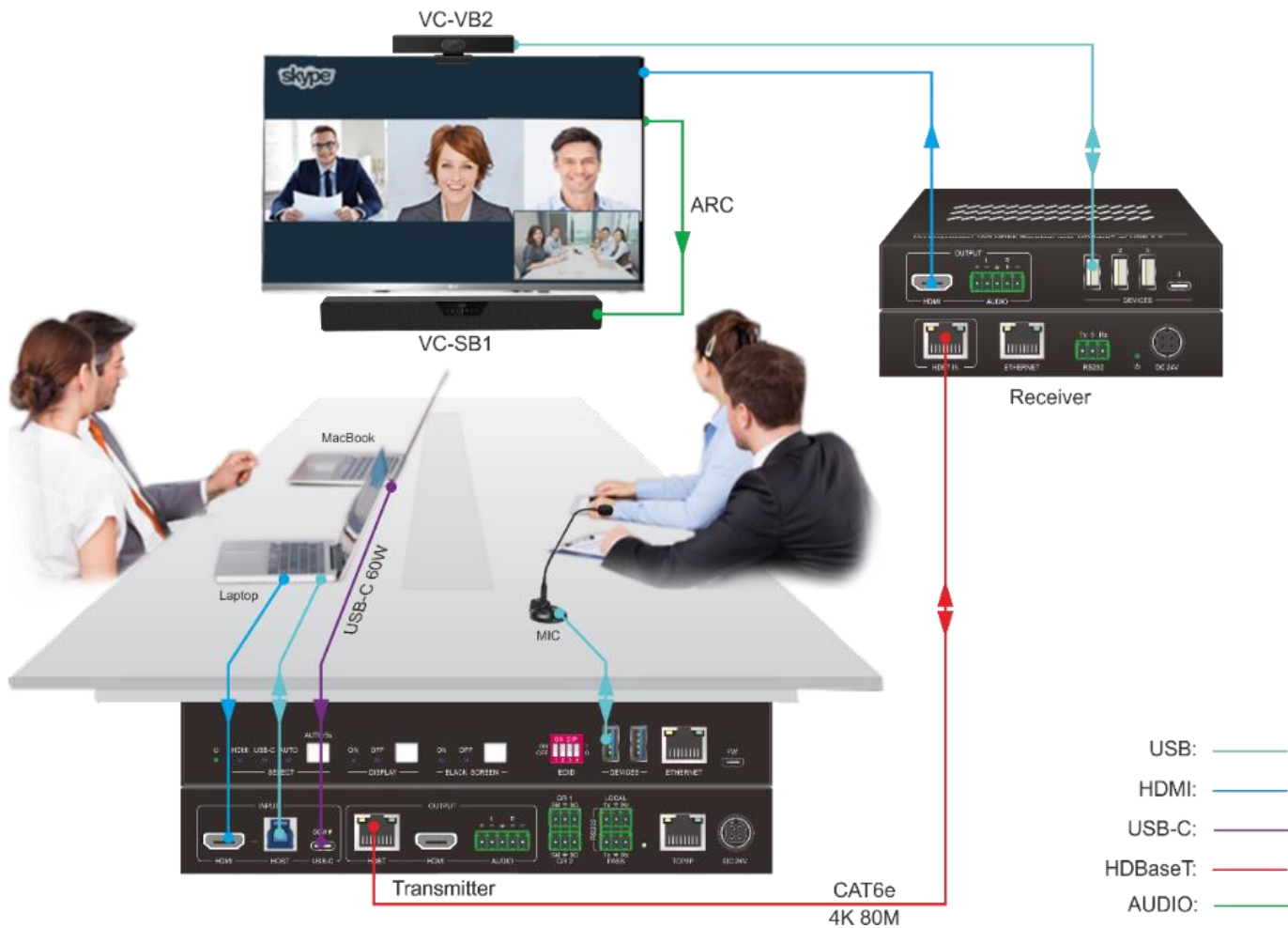

# SCU21T-KVM

## 79121-KVM User Manual

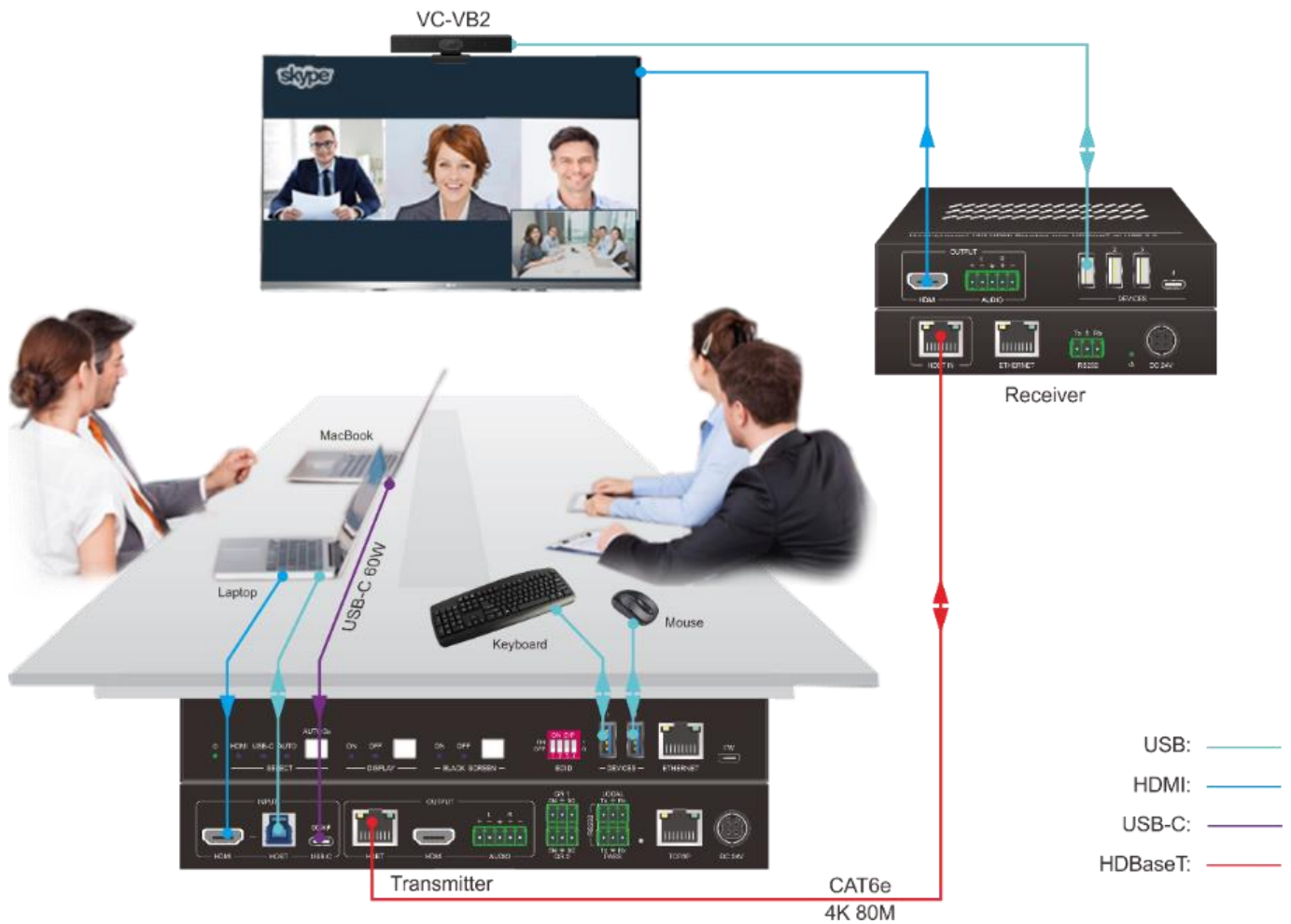

# SCU21T-KVM

## 79121-KVM User Manual

### 8. Panel Drawing

